

Gas Condensing Technology

## VITODENS® 100-W

Space Heating and On-Demand DHW with Combi boiler

**VIESMANN**



**Heating Systems** ◀

**Industrial Systems**

**Refrigeration Systems**

## Gas Condensing Technology

## Vitodens 100-W – 21 to 125 MBH Space Heating and On-Demand DHW with Combi boiler



Stainless steel, Viessmann-made Inox-Radial heat exchanger

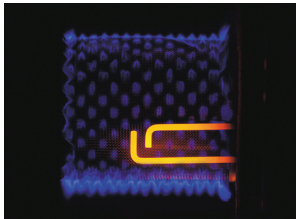

Low-emission, Viessmann-made Matrix cylinder burner



Backlit LCD touchscreen

### Every home. Every budget.

With its outstanding design and price/performance ratio, the Vitodens 100-W is the perfect mix of performance and value. Its compact design, zero clearance to combustibles and extremely quiet operation make the Vitodens 100-W an ideal choice even in the smallest of spaces. Plus, with a limited residential lifetime warranty, you can be sure your investment will deliver long-lasting value year after year.

### Reliable and consistent performance

Stainless steel is the best choice for long-term reliability. That's why the Vitodens 100-W is equipped with a stainless steel Inox-Radial heat exchanger and Matrix cylinder burner. Developed and manufactured by Viessmann, these high-quality stainless steel components maximize performance and reliability. Plus, the "self-cleaning" heat exchanger contributes to the boiler's long service life and dependable performance.

### Outstanding versatility

The Vitodens 100-W offers the right solution for every demand – from multiple venting options to fuel flexibility (NG or LP) right out of the box. Plus, installation, service and maintenance are designed to be fast and easy with all pipe connections located at the bottom and serviceable components easily accessible from the front.

### Helps you save

Select an easy-to-use room thermostat and utilize the boiler's on-board control, which automatically adjusts the boiler water to outdoor temperatures. This not only boosts fuel savings, but also keeps your home warm and comfortable at all times.

### User-friendly touchscreen control unit

The Vitodens 100-W gas condensing boilers are controlled by the new, one hand touchscreen control with enhanced programming. The backlit LCD touchscreen display offers excellent readability even under poor lighting conditions.

### On-demand DHW with Vitodens 100-W, B1KA Combi boiler

High-efficiency domestic hot water (DHW) and space heating are now combined in the new Vitodens 100-W, B1KA Combi boiler. Say goodbye to your DHW tank and experience reliable hot water all day long with an outstanding flow rate of up to 3.7 GPM†, plus added cost savings with the energy-saving on-demand indirect-fired design. Installation is easy with the new Combi boiler as the brazed-plate stainless steel heat exchanger, pressure bypass valve, DHW temperature and flow sensors, 3-speed pump and 3-way diverting valve are built-in to form one compact, lightweight, space saving unit.

### Capacities (NG Inputs) Btu/h

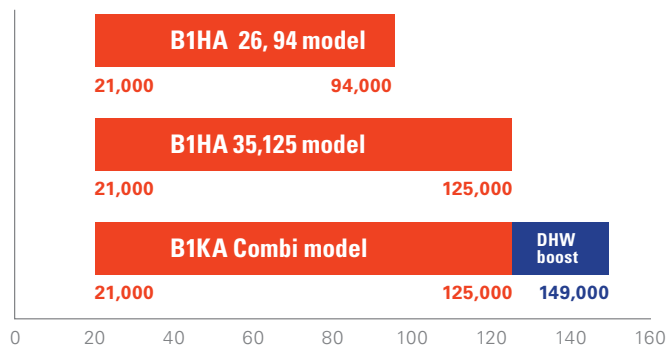

Optimized load matching with up to 6:1 turndown ratio

† At a 69 °F maximum temperature rise with Vitodens 100, B1KA 35

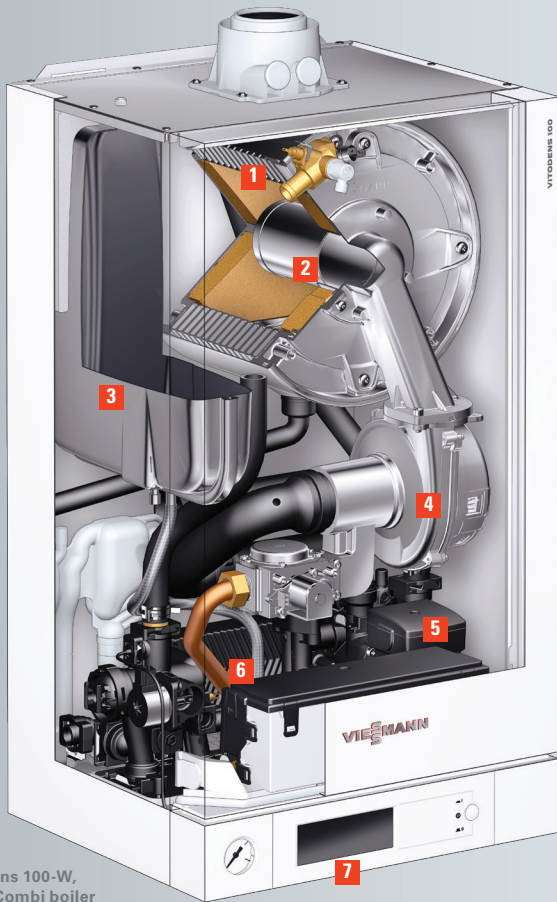

- 1 Stainless steel Inox-Radial heat exchanger
- 2 Modulating MaxtriX cylinder burner
- 3 Integral heating expansion tank (B1KA Combi boiler only)
- 4 Variable speed combustion fan for quiet and economical operation
- 5 Integrated pump
- 6 Brazed -plate heat exchanger for convenient DHW heating (B1KA Combi boiler only)
- 7 Backlit LCD touchscreen

Vitodens 100-W,  
B1KA Combi boiler

(Actual product varies from illustrated product image)

#### Benefits at a glance – Vitodens 100-W, B1HA

- Fits any home and budget with high performance at an attractive price
- Outstanding efficiency of 95% A.F.U.E. on all models
- Fully-modulating input eliminates energy waste
- Lasting performance with proven Viessmann stainless steel Inox-Radial heat exchanger constructed to CSA B51 and ASME Section IV
- Low-emission combustion with fully-modulating Viessmann stainless steel Matrix cylinder burner for natural gas or propane; factory calibrated
- User-friendly backlit LCD touchscreen boiler control with vent length up to 200' and multiple venting options; rigid and flexible PP(s) vent options
- Suitable for altitude levels of up to 10,000 ft. / 3,000 m
- Simple to install and service with 4 pipe hydronic connection design with built-in primary pump and diverter valve
- Extremely quiet operation; quieter than most refrigerators
- Limited lifetime warranty in residential applications
- Ideal application for apartments, condos, cottages, single-family homes, or installs where space is at a premium

#### Benefits – Vitodens 100-W, B1KA Combi boiler

- All the benefits of a Vitodens 100-W boiler, plus built-in on-demand domestic hot water (DHW) – no need for an additional storage tank
- DHW at the snap of your fingers all day long! Up to 3.7 GPM!
- Optimized load matching with up to 6:1 turndown ratio
- Energy-saving and low-cost, on-demand indirect-fired DHW production
- Conforms to NSF/ANSI 372 for Low Lead Content
- Quality you can count on! Stainless steel heat exchanger, built-in pressure bypass and 150 psig working pressure rating (on DHW side only)
- Reliable and consistent DHW supply with built-in DHW temperature and flow sensors
- Complete space / DHW heating management by boiler control, powerful built-in 3-speed pump and diverting valve

# Technical Specifications

## Vitodens 100-W B1HA, B1KA

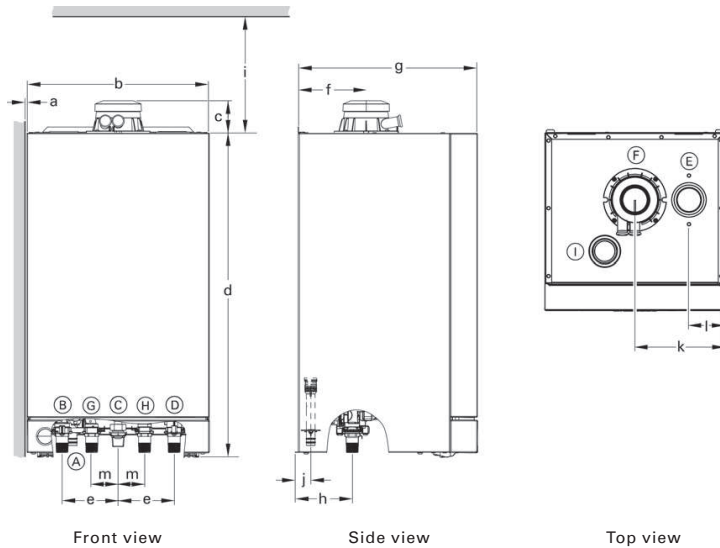

### Dimensions

- a 1/4" - both sides of the boiler
- b 15 3/4"
- c 2 5/8"
- d 27 1/2"
- e 4 7/8"
- f 6"
- g 15 3/4"
- h 5"
- i 9 3/8" minimum
- j 1 1/8"
- k 7 7/8"
- l 3 3/8"
- m 2 1/4"

### Vitodens 100-W, B1HA series and B1KA Combi boiler

#### Legend

- A Condensate drain, plastic hose Ø 1 in.
- B Boiler water supply, NPT 3/4 in. (male thread)
- C Gas connection, NPT 3/4 in. (male thread)
- D Boiler water return, NPT 3/4 in. (male thread)
- E Combustion air opening for double pipe system
- F Combustion air opening for coaxial system
- G - For B1HA series, DHW tank heating supply, NPT 3/4 in. (male thread)
- For B1KA combi, DHW, NPT 1/2 in. (male thread)
- H - For B1HA series, DHW tank heating return, NPT 3/4 in. (male thread)
- For B1KA combi, DHW, NPT 1/2 in. (male thread)
- I Opening for pressure relief valve

### Vitodens 100-W B1HA, B1KA

Vitodens		B1HA	B1HA	B1KA
Model		26, 94	35, 125	35, 125
Maximum input (NG)	MBH	94	125	125
Minimum input (NG)	MBH	21	21	21
NET AHRI Rating	MBH	76	101	101
AFUE	%	95	95	95
<b>Dimensions</b>				
Depth	inches	15.75	15.75	15.75
Width	inches	15.75	15.75	15.75
Height	inches	30.25	30.25	30.25
Weight	lbs	79.4	79.4	90
Boiler water content	USG	1.02	1.02	1.02
Heat exchanger surface	ft <sup>2</sup>	12.96	12.96	12.96
Maximum operating pressure	psig	45	45	45
<b>Minimum gas supply pressure</b>				
Natural Gas	"w.c.	4	4	4
LPG	"w.c.	10	10	10
Boiler water temperature maximum	°F	176	176	176
Adjustable high limit (AHL) range space heating (steady state)	°F	86-176	86-176	86-176
<b>Boiler connections</b>				
Gas valve connection	NPTM	3/4	3/4	3/4
Boiler heating supply and return	NPTM	3/4	3/4	3/4
<b>Vent connections<sup>1</sup></b>				
2-Pipe vent (PPS/CPVC) <sup>2</sup>	Ø inches	2	2	2
2-Pipe intake (PPS/CPVC or PVC) <sup>2</sup>	Ø inches	2	2	2
Coaxial	Ø inches (mm)	2/4 (60/100)	2/4 (60/100)	2/4 (60/100)

<sup>1</sup> For detailed information refer to the Vitodens Venting System Installation Instructions.

<sup>2</sup> If using CPVC, order adapter number 7134769



Technical information subject to change without notice.  
9450370 2018 Printed in USA

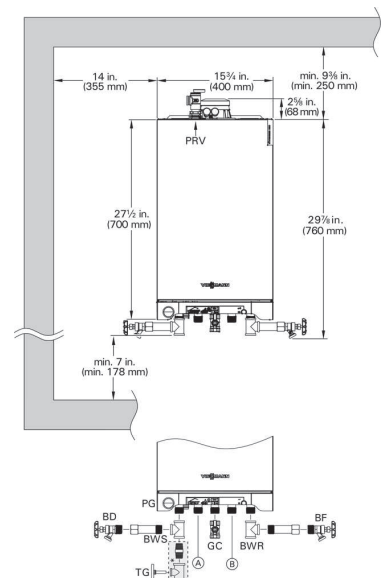

#### Legend

- (A) - DHW tank heating supply for B1HA boilers  
- DHW for B1KA boiler
- (B) - DHW tank heating return for B1HA boilers  
- DCW for B1KA boiler

- BWR Boiler water return
- BWS Boiler water supply
- BD Boiler drain
- BF Boiler fill
- GC Gas connection
- PRV Pressure relief valve
- PG Pressure gauge
- VC Venting connection
- TG Temperature gauge
- \* Field supplied

#### Standard boiler equipment includes

- wall-mount boiler and installation fittings c/w 30 psig relief valve
- pressure gauge
- gas shut-off valve
- two fill/drain valves
- all mounting hardware
- outdoor temperature sensor
- tank temperature sensor (B1HA)
- DHW 150 psi relief valve (B1KA)
- Vent lengths up to 200'

Viessmann Manufacturing Company (U.S.), Inc  
45 Access Road  
Warwick, RI 02886  
1-888-288-0667  
viessmann.com